

# Star Seiki is a general manufacturer of cartesian coordinate robots.

We are one of the leading manufacturers in the industry, having shipped a cumulative total of 233,000 unloaders for plastic injection molded products (as of 2022).

We apply the know-how regarding mechanisms, controls, safety measures, and operation that we have built up through robot development to palletizers.



Keep up to date with all our news

Follow us on social media.



## STAR SEIKI CO., LTD.

Head Office & Factory: 3-133, Akita, Ohguchi-cho, Niwa-gun, Aichi Pref., 480-0132 PHONE 0587-95-7551

### North America

U.S.A. STAR AUTOMATION, INC. WISCONSIN (HEADQUARTERS)  
 U.S.A. STAR AUTOMATION, INC. MICHIGAN OFFICE  
 U.S.A. STAR AUTOMATION, INC. CALIFORNIA OFFICE  
 U.S.A. STAR AUTOMATION, INC. INDIANA OFFICE

U.S.A. STAR AUTOMATION, INC. GEORGIA OFFICE  
 U.S.A. STAR AUTOMATION, INC. RHODE ISLAND OFFICE  
 U.S.A. STAR AUTOMATION, INC. TENNESSEE OFFICE  
 Mexico STAR SEIKI MEXICO S.A. DE C.V.

Click here for details 

[www.starseiki.com](http://www.starseiki.com)

### South America

Brazil STAR SEIKI BRASIL LTDA.

### Europe

Italy STAR AUTOMATION EUROPE S.P.A.

### Asia

China STAR SEIKI (SHANGHAI) CO., LTD.  
 China STAR SEIKI (SHANGHAI) CO., LTD. DALIAN OFFICE  
 China STAR SEIKI (SHANGHAI) CO., LTD. TIANJIN OFFICE  
 China STAR SEIKI (SHANGHAI) CO., LTD. QINGDAO OFFICE  
 China STAR SEIKI (SHANGHAI) CO., LTD. SUZHOU OFFICE  
 China STAR SEIKI (SHANGHAI) CO., LTD. WUHAN OFFICE  
 China STAR SEIKI (SHANGHAI) CO., LTD. SHENZHEN BRANCH  
 China STAR SEIKI (SHANGHAI) CO., LTD. YUYAO OFFICE  
 China STAR SEIKI (SHANGHAI) CO., LTD. GUANGZHOU OFFICE  
 China STAR SEIKI (SHANGHAI) CO., LTD. XIAMEN OFFICE  
 China STAR SEIKI (SHANGHAI) CO., LTD. CHONGQING OFFICE  
 China STAR SEIKI (SHANGHAI) CO., LTD. CHENGDU OFFICE  
 China STAR AUTOMATION (SHENZHEN) CO., LTD.  
 China STAR SEIKI (XIANG YANG) CO., LTD.  
 China STAR SEIKI (HONGKONG) CO., LTD.  
 Taiwan STAR SEIKI TAIWAN, INC.

Taiwan STAR SEIKI TAIWAN, INC. TAINAN OFFICE  
 Taiwan STAR SEIKI TAIWAN, INC. TAICHUNG OFFICE  
 Korea STAR SEIKI KOREA CO., LTD.  
 Thailand STAR SEIKI (THAILAND) CO., LTD.  
 Thailand STAR SEIKI (THAILAND) CO., LTD. PRACHINBURI BRANCH  
 Singapore STAR SEIKI SINGAPORE PTE. LTD.  
 Malaysia STAR SEIKI (SINGAPORE) PTE. LTD. K.L. BRANCH  
 Malaysia STAR SEIKI (SINGAPORE) PTE. LTD. J.B. BRANCH  
 Indonesia PT. STAR SEIKI INDONESIA  
 Indonesia PT. STAR SEIKI INDONESIA BEKASI BRANCH  
 Indonesia PT. STAR SEIKI INDONESIA SURABAYA BRANCH  
 Philippines STAR SEIKI PHILIPPINES INC.  
 Vietnam STAR SEIKI (VIETNAM) CO., LTD.  
 Vietnam BRANCH OF STAR SEIKI (VIETNAM) CO., LTD. IN HO CHI MINH CITY  
 India STAR SEIKI INDIA PRIVATE LIMITED  
 India STAR SEIKI INDIA PRIVATE LIMITED CHENNAI OFFICE



2024-01EN

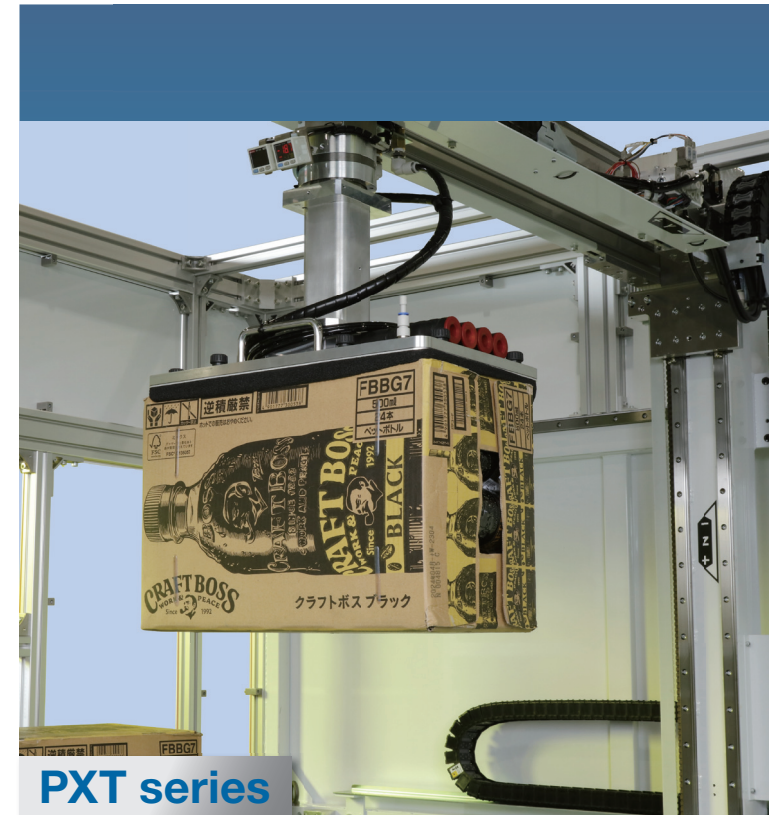

Robot for stacking cardboard boxes

# Cartesian Robot Palletizer



Watch the video

## STAR SEIKI CO., LTD.



# On behalf of humans

Improve stacking work without hassle.

## Stacking work issues

Not enough workers

Want to mechanize but don't have enough space

The factory ceiling is too low to install robots

Can't install a compressor

Don't have anyone skilled in machine operation



## A palletizer can help you solve logistical challenges.

Reduce time spent on standby and waiting to load trucks

Improve systems for shipping and receiving

Improved situation with respect to shortage of staff in warehouse

Work style reform (working hours, wages)

Make stacking work more efficient

Greater efficiency and automation

## Handle issues like these

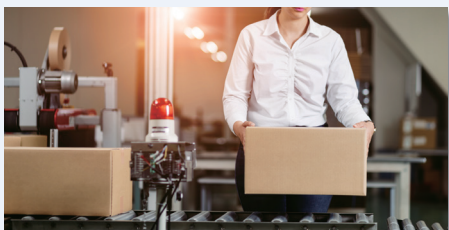

- ✓ Workplaces with many women and elderly people
- ✓ Dusty, high-temperature, low-temperature, or high humidity environments
- ✓ Continuous work for long hours
- ✓ Stacking in specified quantities
- ✓ Trouble such as cargo collapse

## Palletizers are making inroads in various industries

Food



Cosmetics



Pharmaceuticals



Warehouse



Beverages



## Effects of Adoption

In the case of Company S

- Work transferring goods to a six-wheel cart
- Introduced two PXW-1420s



**Personnel** Staff: 10 people → Staff: **1** person

Nine staff members could be assigned to different tasks

**Quantity processed** 3,500 boxes/day → **7,200** boxes/day

Improved productivity and work efficiency on the line

**Labor costs** 13.5 million yen/year → **3.24** million yen/year

Significant reduction in labor costs

\* Cases in Japan



# Easy to deploy

## Can be installed in spaces with low ceilings

Can be installed in spaces where height is limited, such as a clean rooms

Example of palletizer installed in a space with low ceilings (electronics manufacturer)



## Flow line can be used effectively on plant floor

The flow line is in the same direction, allowing for efficient operation even when using multiple pallets.

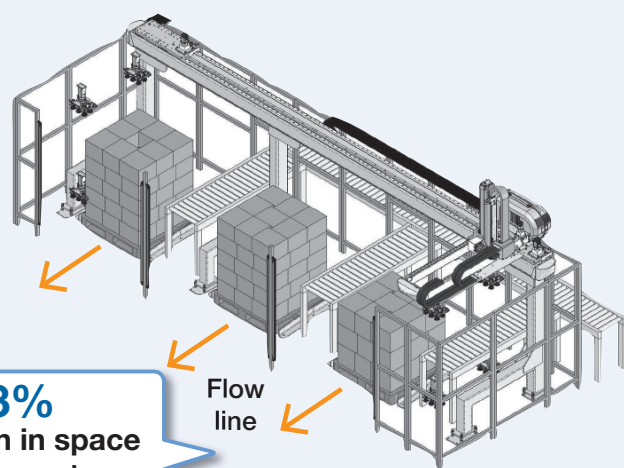

**63%** reduction in space (Compared to articulated robots)

When an articulated robot uses multiple pallets, the flow lines differ.

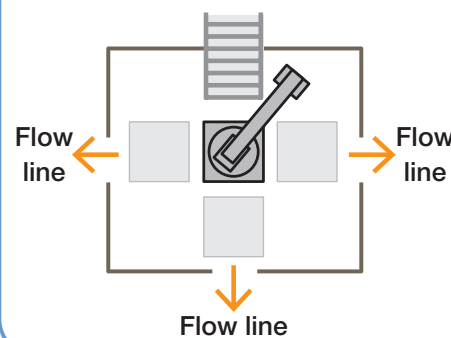

# Easy to operate

Heavy labor   Space   Overall height   Inefficiency   Cost

Solve 5 issues in stacking operations

## Reallocate human labor from rote work, to work only humans can do

Freeing valuable personnel from heavy labor allows them to be assigned to work that only humans can do. This allows limited human resources to be used more effectively.



## Easy operation by touch panel

Touch panel operation makes the palletizer easy to operate.



7-inch wide screen

## Practical safety measures

We use our experience with unloaders to implement practical safety measures. We can also provide individualized safety measures by customer request.



The palletizer sits on casters, making it safer to move for things like changes to the layout of the plant floor. (Equipped as standard on the PXT Series)

Operation stops instantly if someone enters the work area. (Equipped as standard on the PXT Series)



## Examples of adoption

PXT-1220: Food product company



PXW-1550: Chemicals company



## Make stacking work more efficient (reference)

The effects will be easy to see

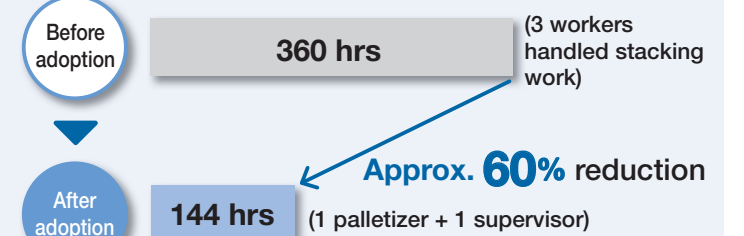

The cited figures are for reference only. They may vary depending on conditions.



# Robot Palletizer for low overall height

## PXT series PXT-1220A/PXT-1220+/ PXT-1235

### PXT-1220+

Handles A3  
Size packages.



Watch the video

Load capacity and stacking  
height can be individually  
adjusted.

2,685 mm

2,025 mm

An overall height of 2,000 mm or  
less ensures they effectively uti-  
lize the smallest amount of space.

(\*The overall height of PXT-1235 is 2,214 mm.)

2,000 mm  
(\* Signal light  
not included.)

Can also be used  
together with pallets.

### PXT-1220A

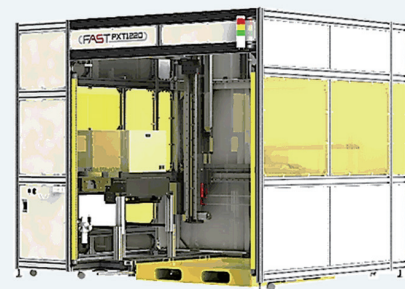

Even easier to  
use than before.

#### ► Payload

Supports up  
to **20 kg** PXT-1220A/  
PXT-1220+

(Including robot hand weight)

Supports up  
to **35 kg** PXT-1235

(Including robot hand weight)

#### ► Processing capacity

**6.2 boxes**  
/min PXT-1220A/  
PXT-1220+

**8.1 boxes**  
/min PXT-1235

\*Based on our evaluation criteria

#### ► Size

PXT-1220A

2,385 (L) × 2,025 (W) × 2,000 (H) mm

PXT-1220+

2,685 (L) × 2,025 (W) × 2,000 (H) mm

PXT-1235

2,488 (L) × 1,980 (W) × 2,214 (H) mm

(\* Width and height does not include signal light.)

### Supports Type T11 to T14 pallets

Flexibly handles stacking work.

T11

1,100 (L)  
×  
1,100 (W)

T14

1,100 (L)  
×  
1,400 (W)

Commonly used  
pallet sizes

Food, pharmaceuticals	1,100 (L) × 1,100 (W) mm
Frozen food	1,200 (L) × 1,100 (W) mm
Beverages	1,100 (L) × 900 (W) mm
Cosmetics	1,220 (L) × 1,220 (W) mm



(PXT-1200+ equipped as standard)

### Casters for easy movement

The palletizer can be moved around freely  
to accommodate changes in plant layout or  
operating conditions.



Watch the video



### Handles A3 Size packages

Can handle packages up to 450 (L) × 310 (W) mm.



### Option

Pallet feeder

Depalletizing supported  
(Removing packages from the pallet)

Robot hand suction

Servo hand

Example of a suction hand  
(Sliding hand) PAT.P



Patent pending (May 21, 2021)

Example of a pallet feeder

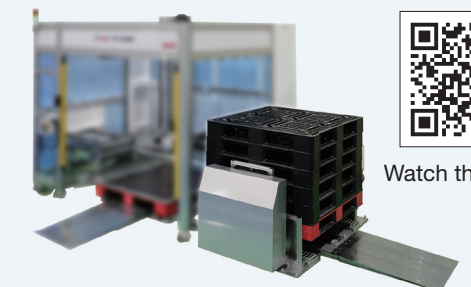

Watch the video



# Multi-palletizer for low overall height

## PXL series PXL-1535

### PXL-1535

Boast a low overall height of 2,421 mm, despite being a multi-tier stacking machine.

Supports stacking heights of 1,700 mm, and OP of 2,000 mm.

(\*150 mm pallet.)

Easily transfer between pallets (T14 to T11).

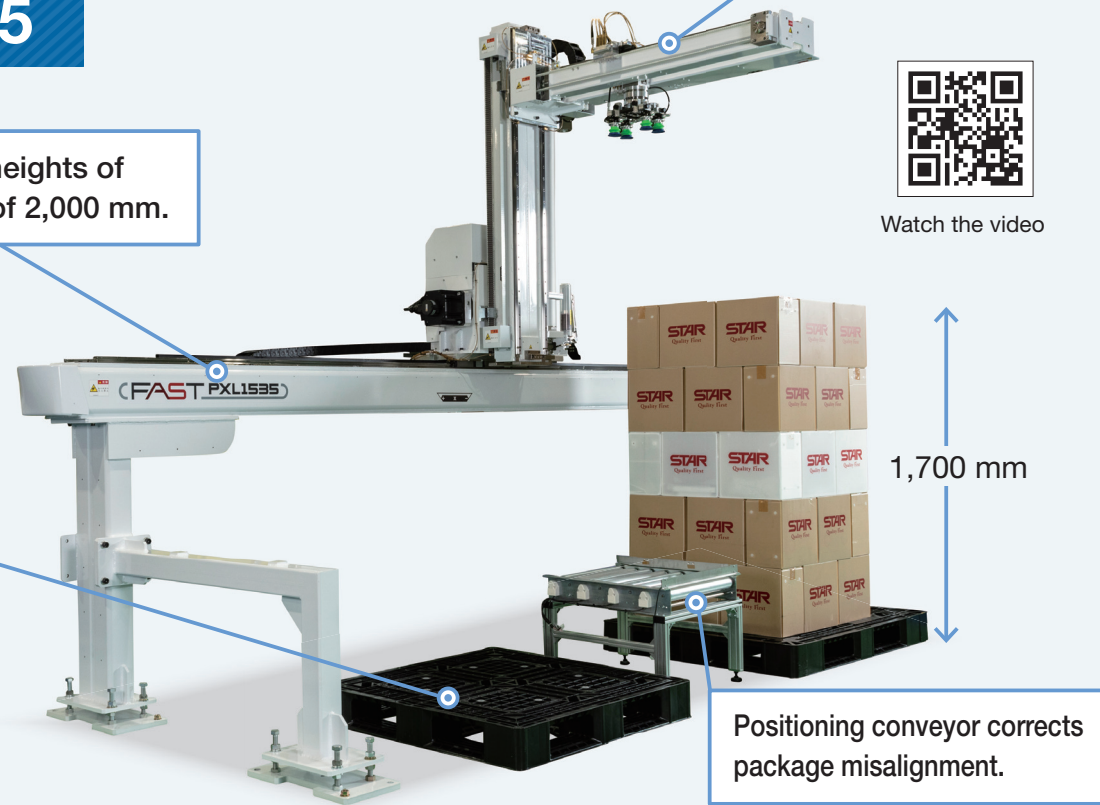

Positioning conveyor corrects package misalignment.

(\*Conveyor sold separately.)

### Easily transfer between pallets

It can correct the package misalignment that tends to occur with multi-tier stacking while transferring between pallets.



### Capable of multi-tier stacking despite low overall height

Even though the overall height is 314 mm lower than the PXW-1535, it can stack packages higher.

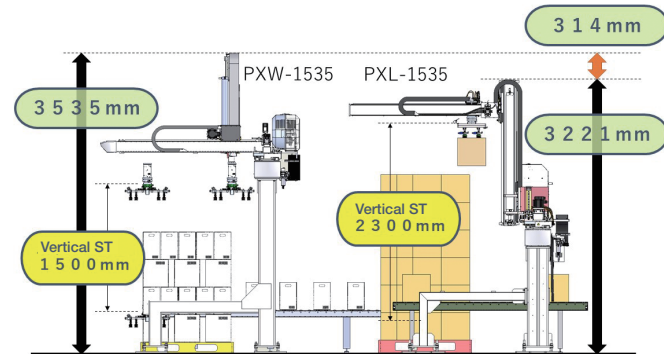

\* Comparison of PXW-1535 and PXL-1535 (optional stroke 800mm)

### ► Payload

Supports up to **35 kg** PXL-1535

(Including robot hand weight)

### ► Processing capacity (transfer)

**6 boxes/min** PXL-1535

\*Figures based on our evaluation criteria.

### ► Size (standard type)

PXL-1535

**4,913 (L) × 2,323 (W) × 2,421 (H) mm**

# Multi-stroke Palletizer

## PXW series PXW-1420/PXW-1535/ PXW-1550

### PXW-1420 standard type

Flexible stroke arrangement.

Fits in small spaces.

Excellent value for money.

Offers high payload.

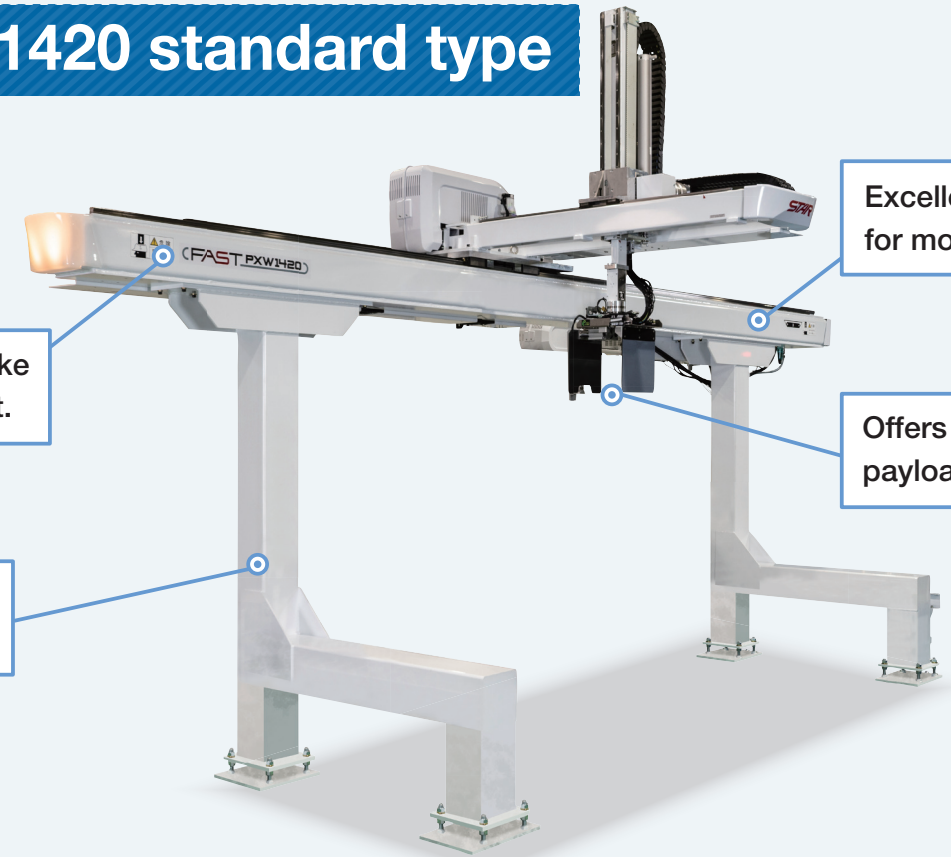

Watch the video

### 2-pallet SPEC (PXW-1420)

- Sort two types of pallets
- Stand-by for transfer pallet

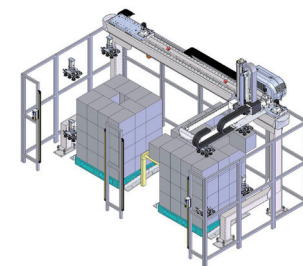

### Depalletizing transfer SPEC (PXW-1420)

- Transfer goods to a six-wheel cart

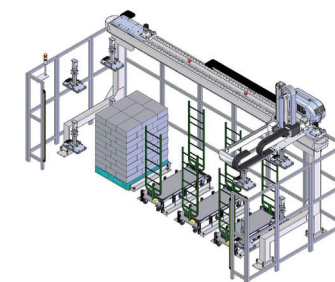

### Requires 63% less space than articulated robots

Installation space for articulated robot

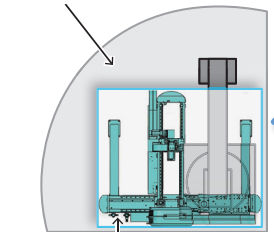

Installation space for PXW series

A palletizer takes up **63%** less space

### ► Payload

Supports up to **20 kg** PXW-1420 (Including robot hand weight)

Supports up to **35 kg** PXW-1535 (Including robot hand weight)

Supports up to **50 kg** PXW-1550 (Including robot hand weight)

### ► Processing capacity

**4.8 boxes/min** PXW-1420/ PXW-1535/ PXW-1550

### ► Size

PXW-1420

**4,748 (L) × 2,390 (W) × 3,486 (H) mm**

PXW-1535

**4,748 (L) × 2,390 (W) × 3,567 (H) mm**

PXW-1550

**4,671 (L) × 2,668 (W) × 3,748 (H) mm**



# Service & Support

We offer compete support for your palletizers

In the unlikely event you have a problem, our nearest STAR GROUP service center will respond promptly.

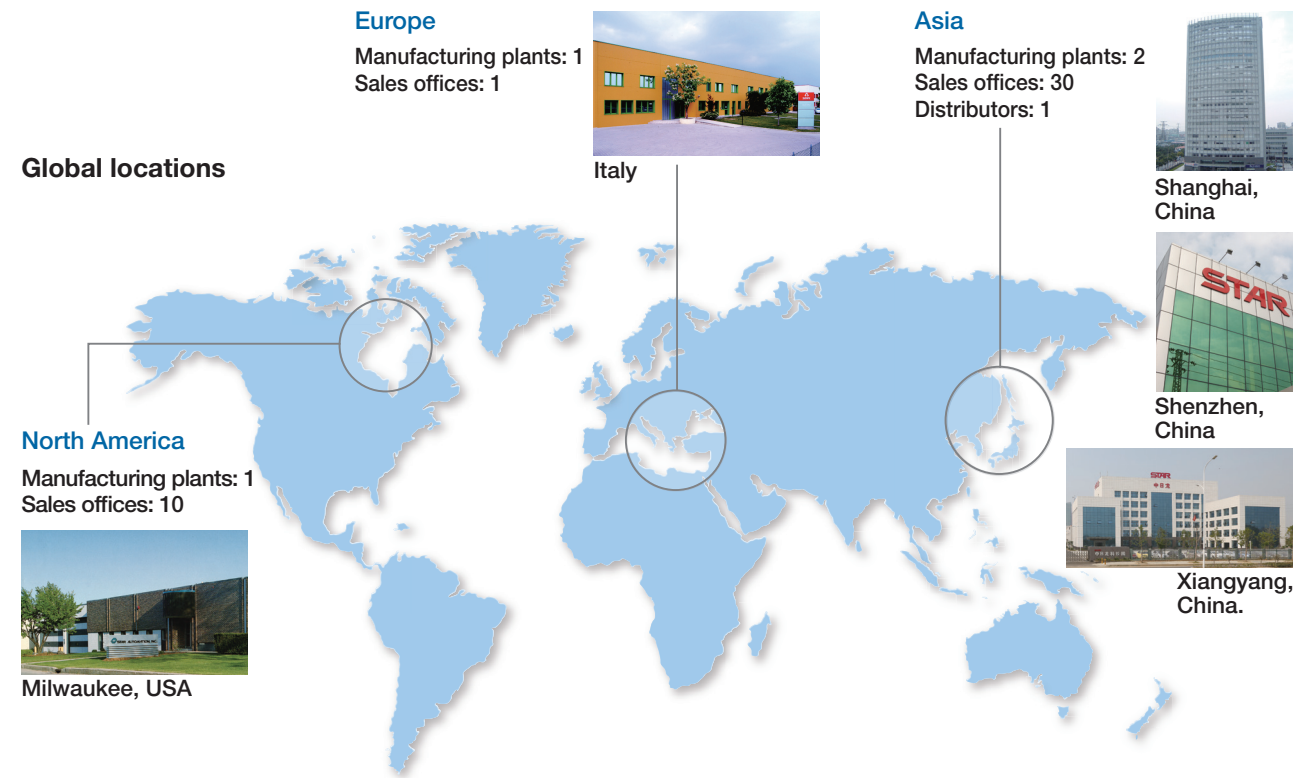

You'll find the latest palletizers on display in our permanent exhibition room "STAR PLAZA."

- Nagoya STAR PLAZA (Head Office)**
- Kanto STAR PLAZA**
- Osaka STAR PLAZA**
- STAR SEIKI THAILAND STAR PLAZA**

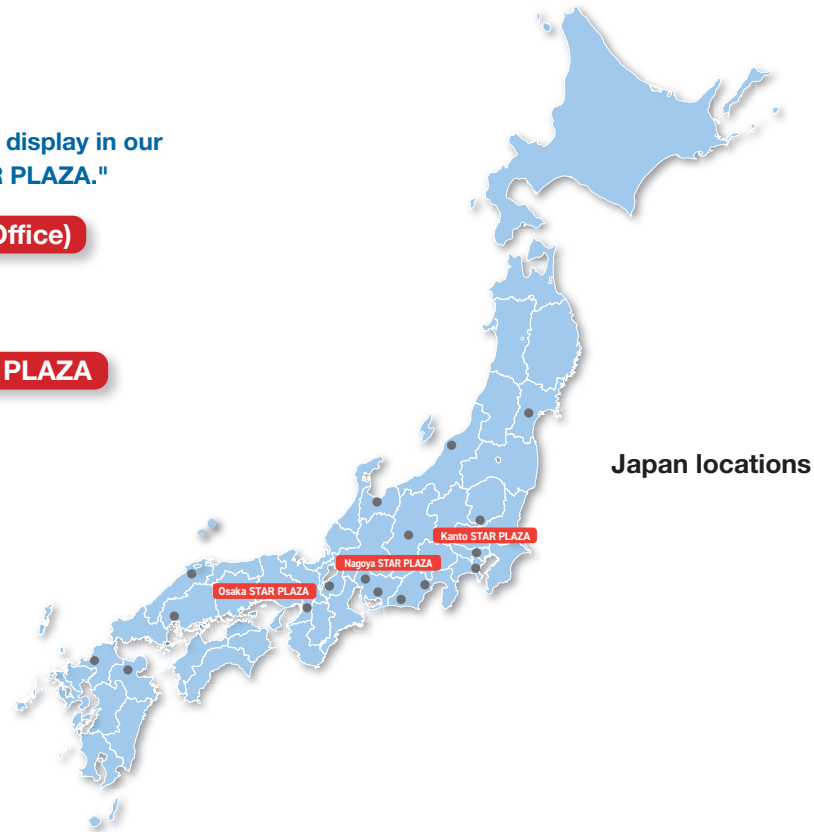

# Product Specifications

	PXT series			PXW series			PXL series
	PXT-1220A	PXT-1220+	PXT-1235	PXW-1420	PXW-1535	PXW-1550	PXL-1535
Normal air pressure [MPa]	0.5	0.5	0.5	0.5	0.5	0.5	0.5
Max. payload (Including robot hand weight) [kg]	20	20	35	20	35	50	35
Vertical axis ( ) OP [mm]	1200 (1400) (1700)	1200 (1400) (1700)	1200	1400 (1200) (1800)	1500 (1800)	1500 (1800) (2000)	1500 (1800) (2300)
Crosswise axis ( ) OP [mm]	900 (1000)	1000	1000	1000 (700)	1000 (1200)	1250 (1550)	1000 (1350)
Traverse axis ( ) OP [mm]	1500	1800	1400	3500 (4500) (5500)	3500 (4500) (5500)	3500 (4500) (5500)	3500 (4500) (5500)
Swivel axis ( ) OP [Degrees]	±160	±160	320(± 160)	320(± 160)	320(± 160)	320(± 160)	±160
Power supply	200 - 220 VAC ±10% 50/60 Hz	200 - 220 VAC ±10% 50/60 Hz	200 - 220 VAC ±10% 50/60 Hz	200 - 220 VAC ±10% 50/60 Hz	200 - 220 VAC ±10% 50/60 Hz	200 - 220 VAC ±10% 50/60 Hz	200 - 220 VAC ±10% 50/60 Hz
Power supply equipment capacity [KVA]	2.1	2.1	8.9	5.5	5.7	7.9	8.9
Max. power consumption [KW]	1.2	1.2	4.6	2.9	3.0	4.1	4.5
Breaker capacity [A]	15	15	30	20	20	30	30
Main unit air consumption [L/min]	15.2	15.2	163.8	91.5	119.8	211.4	103
Main unit weight [kg]	487	518	1044	1093	1100	1287	1445

## Robot hand section air consumption

Sliding hand PAT.P	Air ejector 4-part version	57 L/min × 4 = 228 L/min
	Air ejector 8-part version	57 L/min × 8 = 456 L/min
Sponge suction gripper		755 L/min
Suction gripper for materials bag PAT.P		755 L/min

\* Overall air consumption is the total sum of main unit air consumption plus robot hand air consumption.

## Robot hand examples

